

# smart-house Output Relay with Energy Measurement Type SH2RE16A2E230

CARLO GAVAZZI

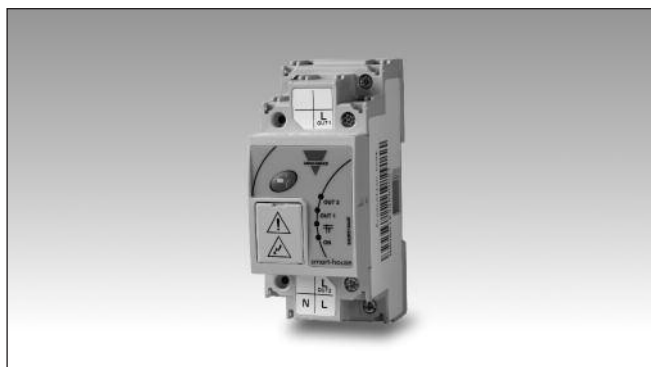

- Two output channels
- Relay load 16 A
- Instantaneous variables readout: current, voltage, power
- Energy measurement: kWh
- 2 DIN housing
- LED indication for power supply, dupline® bus, output1, output2
- Connection to other cabinet modules via local bus

## Product Description

This is a two-relay output module for DIN-rail mounting with energy measurement. Single phase variables:  $V_{LN}$ , A, W. Energy measurements: total kWh. The measured values are then logged in the

SH2WEB24. The outputs are normally OFF. When an activation command is received from the Dupline® bus, the output turns ON and remains ON until the OFF command is received.

## Ordering Key SH 2 RE 16A 2 E 230

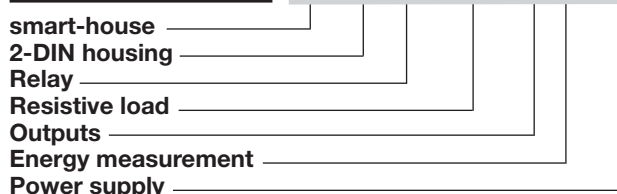

## Type Selection

Housing	Mounting	Relay Max. load	Relay outputs	Supply: 115 to 240 VAC
2 DIN	DIN-rail	16A	2 SPST relay	SH2RE16A2E230

## Output Specifications

Relay outputs	2 SPST relay
Resistive load	AC1 16 A
Mechanical life	$5 \times 10^6$ operations
Electrical life	$1 \times 10^6$ operations, 250 V 12 A
Minimum load	100 mA / 12 V
Operating frequency	60 operations/min
Electrical characteristics	See table
Connection	L <sub>OUT1</sub> : relay output1 L <sub>OUT2</sub> : relay output2

Load	Test conditions	Typical number of operations
250 V, 12 A, $\cos \varphi=1$	1800/h, 50% DC, +70°C	$1.0 \times 10^5$
250 V, 8 A, $\cos \varphi=1$	1800/h, 50% DC, +70°C	$3.5 \times 10^5$
250 V, 4 A, $\cos \varphi=1$	1800/h, 50% DC, +70°C	$5.0 \times 10^5$
250 V, 3 A, $\cos \varphi=1$	1800/h, 50% DC, +70°C	$7.5 \times 10^5$
230 V, 550 W filament lamps $I_{in} \leq 40$ A peak $I_{off} = 2.5$ A	60/h, 8% DC, +22°C	$2.5 \times 10^5$
230 V, 1000 W filament lamps $I_{in} \leq 71.5$ A peak $I_{of} = 4.5$ A	60/h, 8% DC, +25°C	$7.0 \times 10^4$
230 V, 900 W fluorescent tubes (25 x 36 W) parallel compensated, 30 $\mu$ F	360/h, 50% DC, +25°C	$1.0 \times 10^4$
230 V, compressor $I_{of} \leq 21$ A peak $I_{off} = 3.5$ A $\cos \phi = 0.5$	500/h, 20% DC, +25°C	$1.7 \times 10^5$
250 V, 8 A, $\cos \varphi = 0.3$	360/h, 50% DC, +25°C	$1.0 \times 10^5$

## Input Specifications

Keypad	For local ON/OFF switching
--------	----------------------------

## Supply Specifications

Power supply	Overvoltage cat. II (IEC 60664-1, par. 4.3.3.2)
Rated operational voltage	115/240 VAC
Operational voltage range	115/240 VAC $\pm 10\%$
Rated operational power	1 W, 2.5 VA
Connection	Terminals L, N
Power on delay	Typ. 2 s



## Dupline® Specifications

<b>Voltage</b>	8.2 V
<b>Maximum Dupline® voltage</b>	10 V
<b>Minimum Dupline® voltage</b>	5.5 V
<b>Maximum Dupline® current</b>	1 mA

The Dupline® bus is present on the internal bus: the modules can be connected one next to the other without the need of wiring the Dupline® bus. See "Wiring diagram".

## General Specifications

<b>Installation category</b>	Cat. II	<b>Housing</b>	
<b>Dielectric strength</b> Power supply to c and Dupline® to output	4 KV AC for 1 min. 6 KV impulse 1.2/50µs (IEC60664-1, TAB. A.1)	Dimensions	2 DIN module
<b>Address assignment</b>	Automatic: the controller recognises the module through the SIN (Specific Identification Number) that has to be filled in the SH tool.	Material	Noryl
<b>Fail-safe mode</b>	In case of interruption of the smart-house connection, the channel will be forced into a specific optional status as described below.	<b>Weight</b>	150 g
<b>Environment</b> Degree of protection Front Screw terminal Pollution degree Operating temperature Storage temperature Humidity (non-condensing)	IP 50 IP 20 2 (IEC 60664-1, par. 4.6.2) -20° to +50°C (-4° to 122°F) -50° to +85°C (-58° to 185°F) 20 to 80% RH	<b>Approvals</b>	cRUUS, according to UL60950 <b>UL notes:</b> Max room temperature: 40°C A readily accessible disconnecting device shall be added in the building installation
<b>LED's indication</b> Power LED Dupline® LED Output LED	1 green 1 yellow 2 red	<b>CE Marking</b>	Yes
<b>Connection</b> Terminal Cable cross-section Tightening torque	6 screw-type Max. 1.5 mm <sup>2</sup> 0.4 Nm / 0.8 Nm	<b>EMC</b> Immunity - Electrostatic discharge - Radiated radiofrequency - Burst immunity - Surge - Conducted radio frequency - Power frequency magnetic fields - Voltage dips, variations, interruptions Emission - Conducted and radiated emissions - Conducted emissions - Radiated emissions	EN 61000-6-2 EN 61000-4-2 EN 61000-4-3 EN 61000-4-4 EN 61000-4-5 EN 61000-4-6  EN 61000-4-8  EN 61000-4-11 EN 61000-6-3  CISPR 22 (EN55022), cl. B CISPR 16-2-1 (EN55016-2-1) CISPR 16-2-3 (EN55016-2-3)

## Mode of Operation

### Working mode

If the SH2RE16A2E230 is connected to the Dupline® bus and the bus is working properly, the relay module is in STANDARD mode and the green LED is ON. The relay enters LOCAL mode if the push button is pressed or if the bus is faulty or not connected. In LOCAL mode the relay doesn't accept any command from the bus and the green LED will be flashing. The relay can go back to STANDARD mode only when the bus is ok and after one of the following events:

- 1) As soon as the Dupline® bus returns
- 2) After a timeout of 1 minute after a button press
- 3) After a power cycle.

### Push button

The push button is used for local switching ON/OFF of the outputs, without needing to connect the bus for test purposes.

Bus connected

With a short press, the user enters LOCAL mode and the green LED will be flashing; at the same time both the outputs will be switched

ON, if at least one of them is OFF. If both the outputs are ON they will be switched OFF.

Bus not connected or faulty  
If the bus is not connected or faulty, the push button overwrites the fail-state status of the outputs: if at least one output is OFF, both of them will be switched ON. If both the outputs are ON they will be switched OFF. Should all the outputs be configured for the safe-state recycle status, then a short pressure will reset the timer and revert to the original sta-

tus of the outputs.

### Fail/safe condition

The output status of the relays, when the Dupline® bus is not connected or faulty, is programmed via the SH tool and the user can choose between the following options:

1. Outputs always OFF
2. Outputs always ON
3. The two outputs maintain the status they had before the disconnection
4. The two outputs run in a cycle with programmable on and off periods: the

## Mode of Operation (cont.)

user can set both the off and on period from 1 to 255 minutes. The factory setting is outputs always OFF.

### Addressing

If the relay module is connected to the SH2WEB controller, no addressing is needed since the module is provided with a specific

identification number (SIN): the user has only to insert the SIN number in the SH tool when creating the system configuration. Used channels: 2 output channels

### Faulty lamps recognition

If the measured current is lower than 20mA, the relay module gives a message of

faulty load (the connected lamp might be broken). This information can be read by the SH2WEB24, via smart-Dupline® and then shown on the SH Tool if connected to the SH2WEB24.

### Energy measurement

The electrical values measured by the SH2RE16A2E230 are: current, voltage, power,

energy. These readouts are sent to the SH2WEB24 and logged there, the instant values and the logged ones are accessible to the user by connecting to the webserver resident in the SH2WEB24.

## Electrical Values Readout

### Rated values

Current	0 to 32,000 mA
Voltage	103 to 260,0 V
Power	0.1 to 6500,0 W
Energy	0.1 to 99999999.9 kWh with roll over

## LEDs Indication

**Red LED:** 2 output LEDs. Output1: ON if output1 active, OFF if output1 OFF. Output2: ON if output2 active, OFF if output2 OFF. Flashing: output not connected or faulty

**Yellow LED:** if the Dupline® bus is working properly, it is always ON. If there is a fault on the bus it will be flashing. It is OFF if the bus is OFF or not connected.

**Green LED:** Power status. ON: supply ON  
OFF: supply OFF  
Flashing: LOCAL MODE active

## Derating Curve

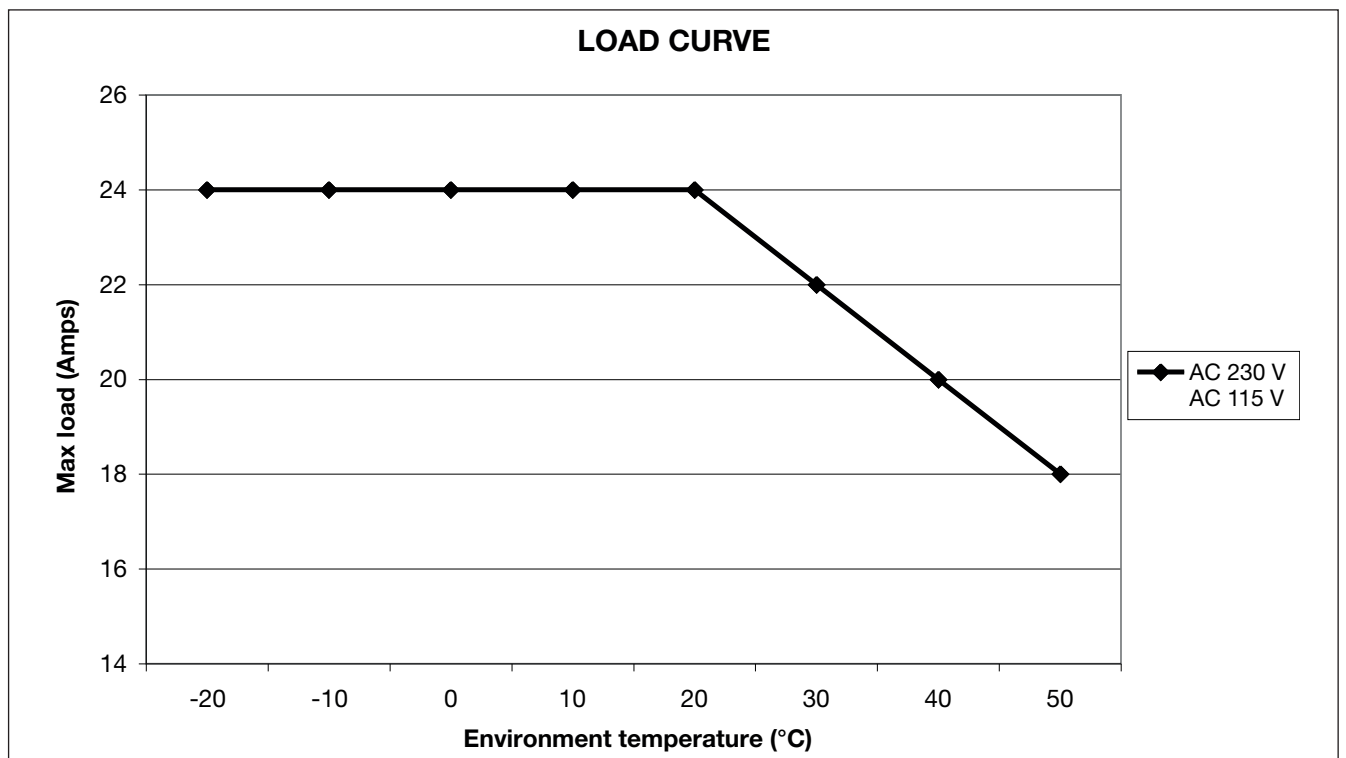

## Dimensions

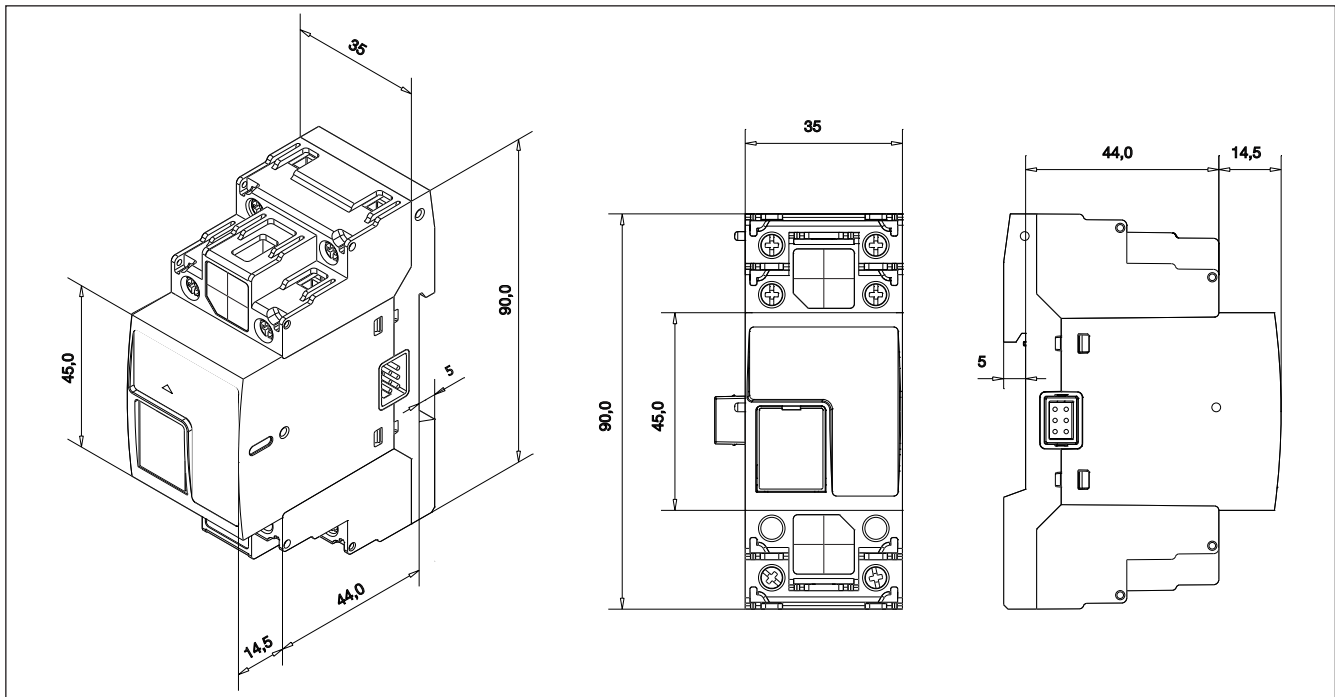

## Wiring Diagrams

